

FEATURING

- **Frequency Range** 470 to 860 MHz (Band V) in a single tube and circuit.
- **Output Power** Rated as a digital amplifier for peak output powers from 45 kW to 75 kW peak and up to 19 kW average power.
- **Long Life** High reliability electron gun with barium aluminate cathode and pyrolytic graphite grid.
- **Simple, Efficient Cooling** Air-cooled cavities and gun. Water cooled body and collector.
- **Simple Tube Exchange** Continuously tunable external cavities, with digital frequency indicators. This means that a replacement tube will be coarse tuned on installation, needing only trimming adjustments.
- **Easy to Tune Input Cavity** Input cavity has a single tuning control. Frequency matching is achieved via a double slug tuner.
- **All Ceramics Aluminium Oxide** No beryllium oxide hazard.

DESCRIPTION

IOTD270E is a high efficiency Inductive Output Tube amplifier for use in the output stage of digital transmitters in UHF television service.

The IOT has an electromagnetically focused electron beam which is density bunched using a rugged grid driven by an RF cavity. The IOT beam power varies with the depth of modulation.

The circuit assembly is designed to reduce tube replacement time to a minimum. The cavities can be detached from the vacuum tube and refitted on a replacement without disturbing the tuning, so that the replacement IOT is coarse tuned at switch-on and requires only trimming adjustments. A feature of the cavity design is that tuning of each cavity including the input cavity, is by means of a single knob. A digital indication of the cavity frequency is provided.

The electron gun and cavities require forced-air cooling; the circuit assembly incorporates a distribution manifold for which the cooling air must be adequately filtered to avoid electrostatic precipitation of dust on insulators.

The IOT body and collector are water cooled and the exit water must be led to a separate heat exchanger (not supplied).

Access to the high voltage electron gun connections of the IOT is via a removable lid on the top of the input cavity. The lid carries a high voltage warning label and the appropriate international symbol. The input cavity is fitted with a microswitch to enable the transmitter circuits to show that the lid is in place and secure. The transmitter can thus be fitted with an executive function to disconnect the high voltage power supply if the input cavity lid is not in place or properly secured.



DIGITAL

ABRIDGED DATA

Frequency range	470 to 860	MHz
Peak output power at IOT flange	45 to 75	kW
Average output power	up to 19	kW
Power gain (see note 1)	20 to 23	dB
Beam voltage	30 to 32	kV

GENERAL

Electrical

Cathode	indirectly heated
Heater voltage (see note 2)	6.25 to 7.5 V dc
Heater current range	20 to 30 A
Cathode pre-heating time	5 minutes
Ion pump to cathode voltage	+3.0 to 4.0 kV
Internal impedance of ion pump supply	500 kΩ approx

Mechanical

Overall length	80.5 cm (31.69 inches) nom
Overall diameter	23.4 cm (9.21 inches) nom
Mounting position	vertical, collector end down
Net weight of IOT	29 kg (64 pounds) approx

Circuit Assembly IMD270

The choice of circuit assembly for the IOTD270 depends on the operating channel. Users should select the appropriate complete circuit assembly (including input cavity) as follows:

Up to channel 40	IMD270A
Channel 40 and above	IMD270B
Electromagnet voltage	5.0 to 7.0 V
Electromagnet current	22 to 26 A
RF input connector	type N coaxial (male)
RF output	3 1/8 inch 50 Ω coaxial line
Net weight of tuning cavities	40 kg (88 pounds) approx
Net weight of magnet assembly	113 kg (250 pounds) approx

Cooling

Air flow to cavities and cathode terminal (see note 3)	2.0 m ³ /min	70.6 cfm
Static pressure head (see note 4)	1.27 kPa	5 inches w.g.
Inlet air temperature	60 °C max	
Minimum water flow rate for body	4.0 l/min	1.1 US gal/min
Body pressure drop at 4.0 l/min	21.1 kPa	3 psi
Minimum water flow required for collector	38 l/min	10 US gal/min
Collector pressure drop at 38 l/min	118 kPa	17.1 psi
Inlet pressure	410 kPa max	60 psi max
Water outlet temperature	70 °C max	
Water inlet temperature	50 °C max	

Tube Protection

Arc detector type MA257E is fitted to each of the primary and secondary output cavities. The beam voltage and drive power must be removed within 100 ms of an arc being established.

Photo-resistor type	NSL 462
Minimum dark resistance	20 MΩ
Resistance at 1 foot-candle	28 kΩ
Resistance at 100 foot-candles	600 Ω
Maximum voltage (peak)	70 V
Maximum temperature	75 °C
Layer	cadmium sulphide
Test lamp	28 V
	0.04 A
Connections	see page 9

MAXIMUM RATINGS (Absolute values)

The transmitter must be provided with a fast disconnect circuit which operates in the event of an internal arc (see note 5). If the maximum rating for any of the other parameters listed below is exceeded, the beam voltage must be removed within 100 ms from the instant at which the rating is exceeded. In either case, the beam voltage must not be re-applied within 5 seconds.

Heater starting current (peak)	60	A
Beam voltage (see note 6)	35	kV
Quiescent current	800	mA
minimum	100	mA
Body current	50	mA
Collector dissipation	50	kW
Load VSWR (see note 7)	1.5:1	
Temperature of any part of tube envelope	130	°C
Peak drive power (see note 8)	750	W
Average drive power	200	W
Grid to cathode bias voltage	-200	V dc
Grid current	±150	mA
Ion pump current (beam on)	20	μA
Peak output power	78	kW
Average output power	20	kW
X-ray radiation	2	μSv/hr
Altitude	3658	m
	12 000	ft

TYPICAL OPERATION

Digital Amplifier Service

Peak output power	45	75	kW
Average output power	11.3	19	kW
Beam voltage	28	32	kV
Beam current	1.0	1.3	A
Grid bias voltage with respect to cathode			see note 9
Peak drive power	380	640	W
Average drive power	100	160	W
Body current (RF)	11	15	mA

NOTES

1. The gain of the IOT is a frequency dependent function and follows the trend shown in Fig. 1 below. A double slug tuner is provided with the IOT input cavity to allow the drive power to be matched into the IOT assembly.

The double slug tuner is supplied separately from the IOT input cavity, and may be installed between the transmitter circulator and the input cavity Heliac® cable.

® Registered trade mark.

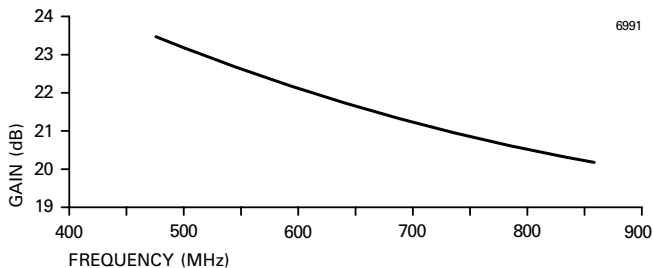

Fig. 1. IOTD270E typical gain characteristic

2. Heater Voltage

The actual heater voltage to be used on a particular IOTD270E is advised with the tube, and should be set at the terminals of the junction box inside the IOT input cavity. The heater voltage should be stabilised to within ± 0.15 V of the recommended value.

Passive Standby and Quick-Start Modes

Where an IOT is being used in a passive standby transmitter, several options exist for the mode of IOT passive operation:

Background Heat Passive Standby Mode

The IOTD270E must be operated with a Background Heat filament voltage 1.5 V less than the nominal heater voltage advised on the test record for a particular IOT, and in no circumstances should the Background Heat heater voltage be less than 5.5 V.

The Background Heat heater voltage should be measured at the terminals of the IOT input cavity junction box in the normal way.

Passive standby is defined as any time period exceeding 30 minutes when the IOT is operated without beam voltage present but with the heater powered. The ion pump and all air cooling must be operated normally in this situation.

If a passive standby transmitter is needed for transmission, the heater voltage should be raised to its rated value and other auxiliary supplies activated. Provided that the grid bias voltage is present, the beam voltage and RF drive may be applied to the tube simultaneously. Precautions must be taken to ensure that the IOT is not overdriven, for example by disabling the transmitter a.g.c. system for a period of about five minutes.

Background heat must have been applied for at least 30 minutes from cold start before the transmitter can be considered available for transmission. Alternatively, both "Active" and "Standby" transmitters may be started from cold using the normal, 5-minute, start procedure. The "Standby" transmitter is then switched to Background Heat and is available to take over transmission if required.

Where Background Heat Passive Reserve is the normal operating mode with a pair of identical transmitters, the transmitter designated as "Standby" must become the "Active" transmitter after a period not exceeding 14 days and must remain designated "Active" for a period of not less than 7 days.

If a hydrogen thyratron crowbar is used in the "Standby" transmitter it should be permanently powered to full operational status.

Filament hours accumulated under Background Heat conditions do not count as warranty hours, provided that the above conditions are met and that there are proper means to distinguish Background Heat hours from normal heater hours.

Soft Start

It is recommended that a soft start procedure should be used in the application of the RF drive when the IOT is powered either from cold or from background heat.

The RF drive may be applied simultaneously with the beam voltage and with a typical rise time of 4 seconds.

Near-instantaneous Start - Quiescent Passive Standby

A nearly instantaneous start from standby can be achieved by operating the "Standby" transmitter in a quiescent passive standby mode where the RF drive only is removed from the IOT and the tube operates with the normal beam voltage applied. The tube draws a quiescent current (which may be lower than the normal value). This slightly reduces overall system efficiency, but ensures that the standby tube is maintained in good condition and is available for near-instant start, subject to normal soft start conditions.

The minimum quiescent current that should be used in this mode is 100 mA. This will ensure the tube maintains a good vacuum and life in standby mode.

Alternatively, the quiescent current may be maintained at the normal operational level, with no adverse effects to the IOT, but with slightly reduced overall system efficiency resulting from greater standby power dissipation.

Mains Interruptions

If mains power is absent for a time less than or equal to 15 seconds, then the transmitter may be re-powered immediately provided that the transmitter logic is active and the power supplies are therefore re-applied in the correct order.

If mains power is absent for a time between 15 seconds and five minutes, then heater voltage should be re-applied for a time equal to the mains absence time before attempting to re-power the IOT, which should then be powered in the normal way.

If mains power is absent for a time in excess of five minutes, then normal cold start-up procedures should be followed.

3. This value applies to transmitters at sea level where the air density is 1.22 kg/m^3 (0.076 lb/ft^3). At high altitudes where the air density is significantly reduced the volume flow must be increased in the ratio of air density at sea level to air density at altitude in order to maintain the mass flow.
4. Measured by a manometer at the input pipe to the circuit assembly.

5. The transmitter must be able to protect both the IOT and itself from damage in the event of an internal arc within the IOT. In such an event, the beam power must be removed from the IOT to limit the energy dissipated within it to less than 20 J. This can be achieved, for example, by the use of a crowbar circuit or a solid-state, high frequency beam voltage power supply. e2v technologies is able to supply a suitable gas discharge tube equipped crowbar designed expressly for use with IOTs. Details will be provided upon request. Users of IOTs should consult their transmitter manufacturer for details of the system employed in particular equipments.
6. The high voltage power supply must be designed and connected to the IOT at start-up in such a way that high voltage overshoots are minimised and do not exceed the stated maximum.
7. Typical operating performance will be obtained for a load VSWR of less than 1.1:1. The tube will not sustain damage for a load VSWR of less than 1.5:1.
8. Protection circuits in the transmitter must ensure that it is not possible for RF drive power to be applied to the IOT in the absence of beam voltage. Failure to do so may result in serious damage to the IOT.
9. Grid bias should be provided by a regulated power supply, adjustable over the range 50 to 150 V, negative with respect to cathode voltage. Adjust to provide the required quiescent current. The supply should be able to sink or source grid current.

INTELLECTUAL PROPERTY RIGHTS

This product is subject to one or more of the following US patents and corresponding patents in other countries:

US5239272	US5536992	US5548245
US5581153	US5606221	US5629582
US5691667	US5736820	US5684364
US5872428	US5796322	US6407495
US5990621	US6781313	

RECOMMENDED COOLANTS

Where there is no possibility of freezing, the coolant should be good quality demineralised water. Where outside temperatures are such that pure water will freeze, then the coolant should be a mixture of equal volumes of pure demineralised water and a commercial ethylene glycol containing appropriate inhibitors and pH buffers. The concentration of glycol may be reduced in accordance with the manufacturer's instructions depending on the minimum temperature at which protection is required. When using a glycol coolant, the coolant flow rate will need to be increased to compensate for the change in heat capacity of the mixture. As an example, for a 50/50 water/glycol mixture, the flow per unit time should be increased by 14% to maintain adequate cooling.

Glycol antifreeze mixtures are prone to thermal degradation with life, especially where the coolant is oxygenated. Consequently, return pipes should discharge below the level of the coolant in reservoir tanks to minimise oxygen take-up. Coolants such as Dowtherm SR1, Dowcal 10 and Ucartherm have been examined by e2v technologies, and are believed to contain suitable pH buffers and inhibitors to make them suitable for IOT cooling.

It is recommended that the coolant is discarded after being used for one winter season to prevent the possibility of corrosion damage occurring. The transmitter should then be flushed, then operated with demineralised water during the summer before being replaced by a fresh glycol mixture before the onset of the following winter.

The use of unbuffered and uninhibited ethylene glycol will lead to corrosion damage to both the cooling system and the IOT and should not be used.

STARTING THE TRANSMITTER AT VERY LOW AMBIENT TEMPERATURES

At very low coolant temperatures, around $-20\text{ }^{\circ}\text{C}$ ($-4\text{ }^{\circ}\text{F}$), the ability of glycol/water mixtures to remove heat is severely reduced. Before powering the IOT at full beam power, the coolant should be at a temperature of at least $5\text{ }^{\circ}\text{C}$ ($41\text{ }^{\circ}\text{F}$). Therefore, at lower temperatures it should be prewarmed by running the IOT on idle current only or by any other appropriate means. For example, allowing the coolant to circulate all night during periods of very low ambient temperature may maintain the coolant temperature around $5\text{ }^{\circ}\text{C}$, due to the dissipation of the energy consumed by the circulating pump, provided that the cooling fan on the heat exchanger is turned off.

OUTLINE OF IOTD270E
(All dimensions without limits are nominal)

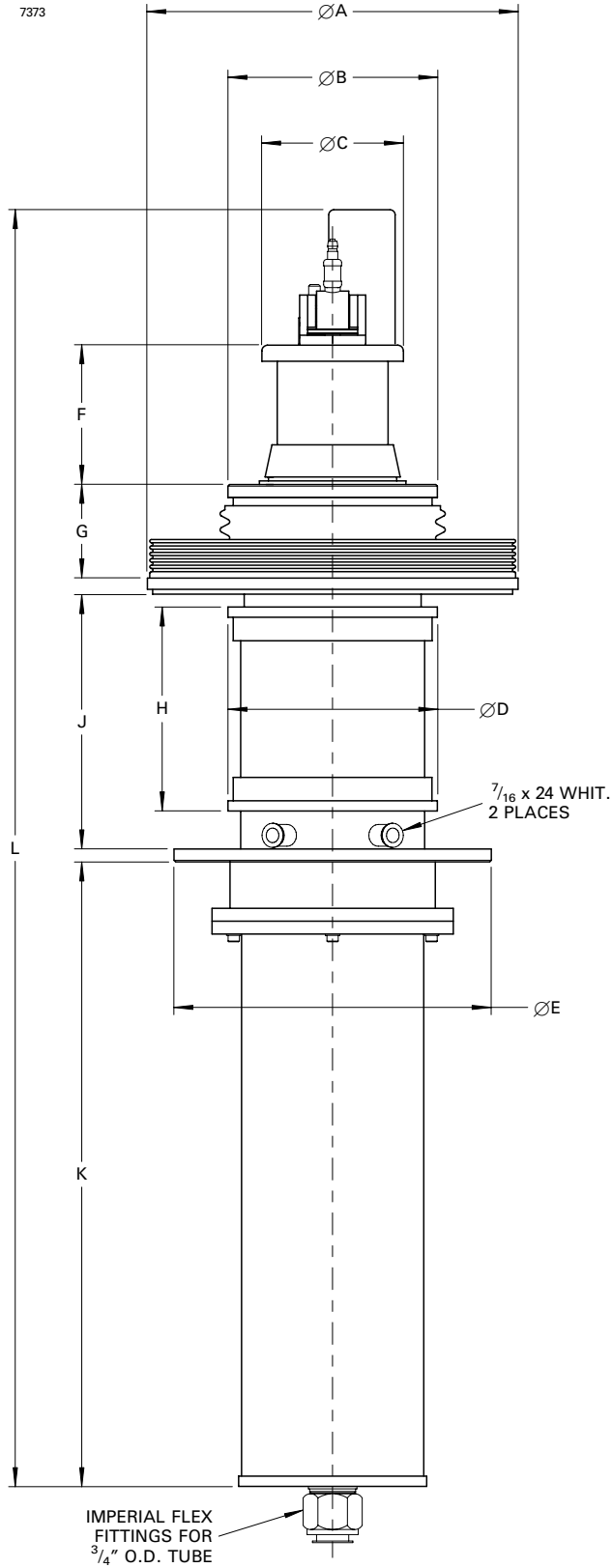

Ref	Millimetres	Inches
A	230.4	9.071
B	130.05 ± 0.30	5.120 ± 0.012
C	93.0	3.661
D	130.05 ± 0.30	5.120 ± 0.012
E	197.15	7.762
F	87.5	3.445
G	58.25	2.293
H	127.0	5.000
J	158.7	6.248
K	385.5	15.177
L	792.5	31.201

Inch dimensions have been derived from millimetres.

Enlarged View of Gun End of Tube

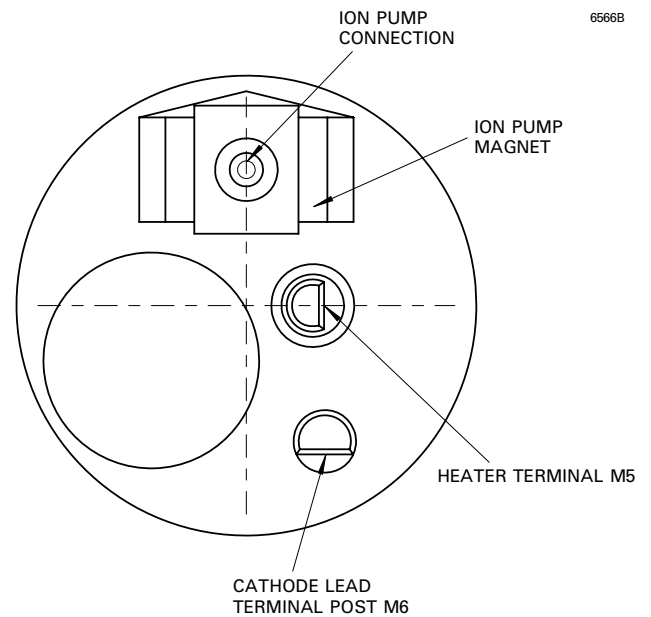

OUTLINE OF CIRCUIT ASSEMBLY IMD270E

(All dimensions without limits are nominal)

7413

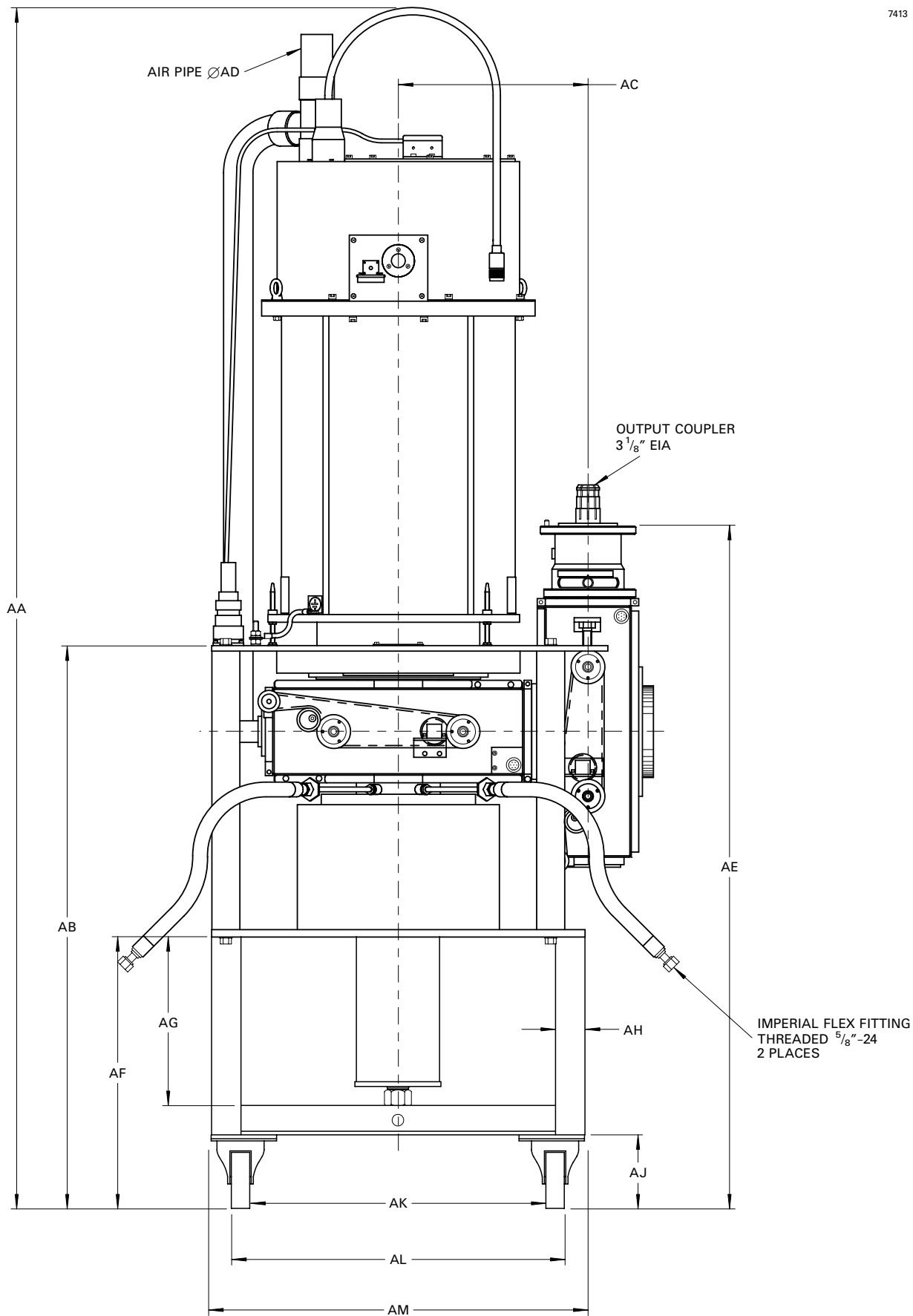

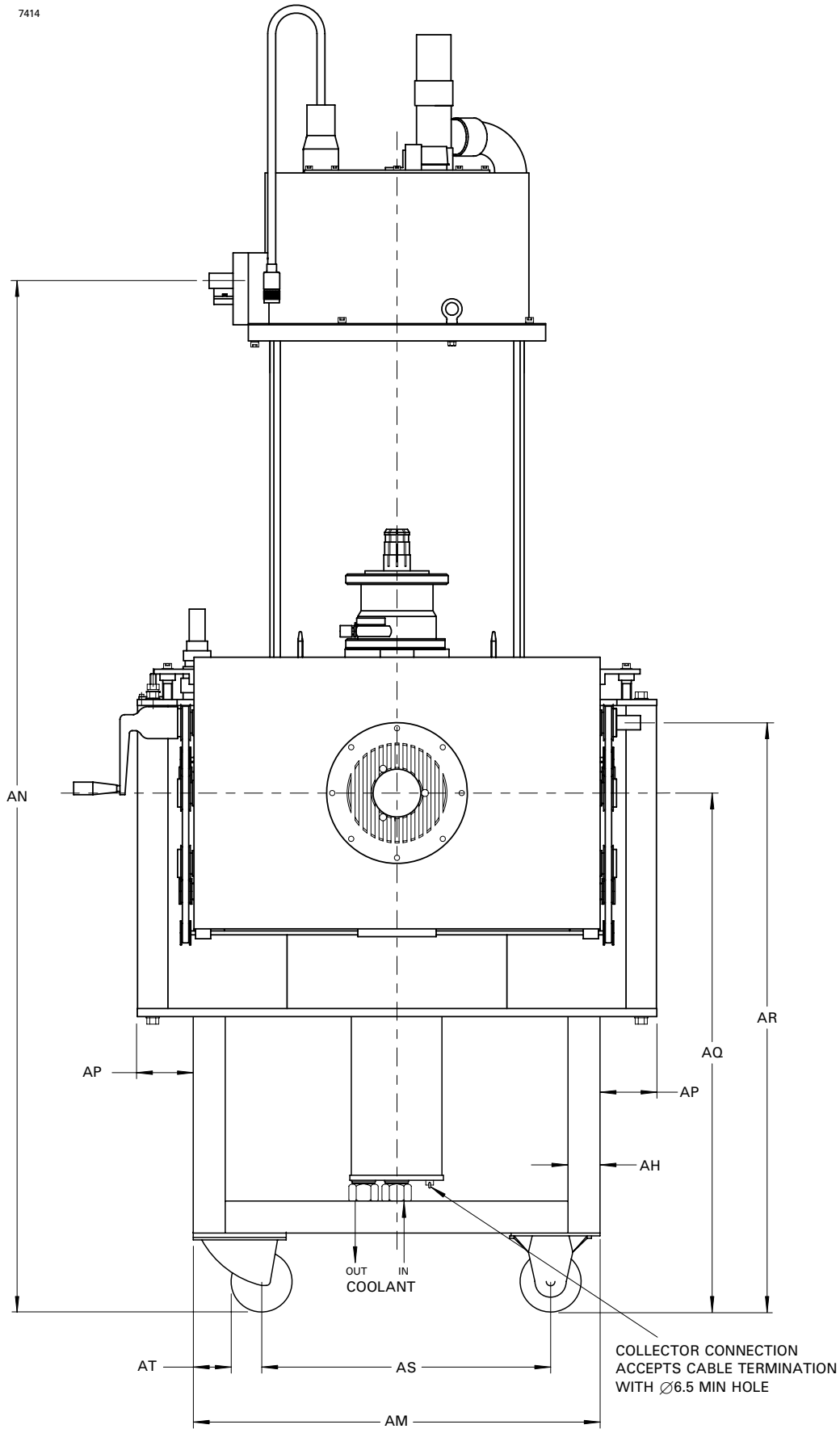

TOP VIEW OF CIRCUIT ASSEMBLY

(All dimensions nominal)

7415

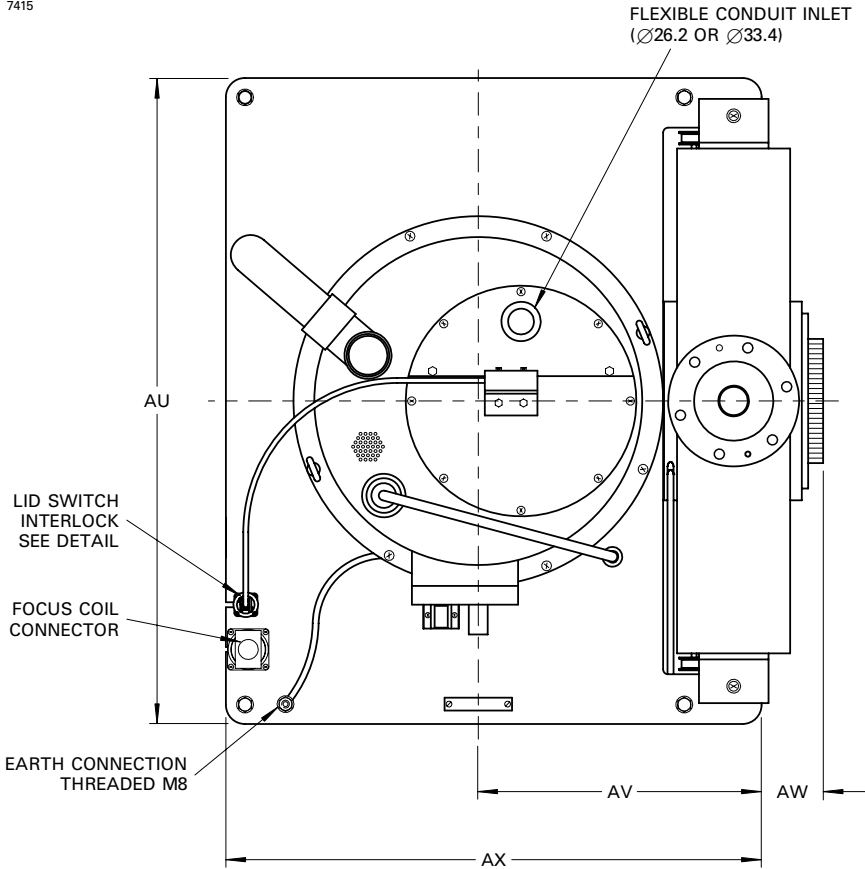

Ref	Millimetres	Inches
AA	1730.0 max	68.110 max
AB	766.0	30.157
AC	258.4	10.173
AD	42.5	1.673
AE	923.2	36.346
AF	370.0	14.567
AG	230.0	9.055
AH	40.0	1.575
AJ	100.0	3.937
AK	403.4	15.882
AL	453.4	17.850
AM	508.0	20.000
AN	1288.47	50.727
AP	71.0	2.795
AQ	648.8	25.543
AR	736.8	29.008
AS	400.0	15.748
AT	25.8	1.016
AU	650.0	25.591
AV	285.0	11.220
AW	62.0	2.441
AX	539.0	21.220

Inch dimensions have been derived from millimetres.

View on Focus Coil Connector

Connections

Pin	Element
A	Lid switch
B	Focus coil positive
C	Lid switch
D	Focus coil negative

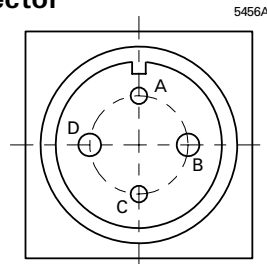

Pins A and C are connected within the circuit assembly for use as an interlock circuit; this connection may be removed by the customer if required for other purposes, but the loss of interlock should be borne in mind.

Lid Switch Interlock

Connections

Pin	Connection
A	Lid switch
B	Lid switch
C	Not connected

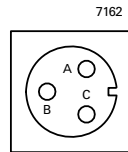

The lid switch is connected between pins A and C of the focus coil connector socket. The lid switch contacts are rated at 480 V ac or 28 V dc at 15 A.

Arc Detector Connections to socket type Amphenol T3476-001

MA257E uses a panel plug and free socket.

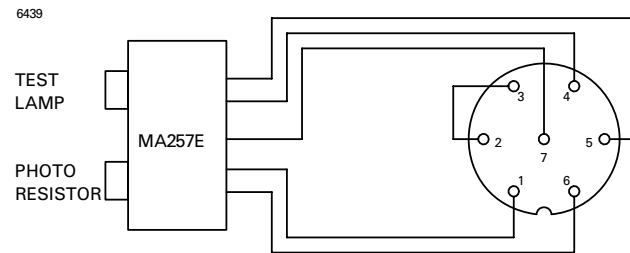

HEALTH AND SAFETY HAZARDS

High power IOTs can be hazardous to life and health if they are not installed, operated and maintained correctly, or if an IOT is damaged. e2v technologies does not accept responsibility for damage or injury resulting from the use of e2v technologies IOTs. Equipment manufacturers and IOT users should ensure that precautions are taken. Appropriate warning labels and notices must be provided on equipment incorporating IOTs and in operating manuals.



High Voltage

Equipment must be designed so that operators cannot come into contact with high voltage circuits. IOT enclosures should have fail-safe interlocked switches to disconnect the primary power supply and discharge all high voltage capacitors before allowing access.



RF Radiation

Personnel must not be exposed to excessive RF radiation. All RF connectors and cavities must be correctly fitted before operation, so that there is no leakage of RF energy. IOTs must not be operated without a suitable RF load at the output and intermediate cavities. It is particularly dangerous to look into open waveguide or coaxial feeders, or transmitter antennae.



X-Ray Radiation

All high voltage devices produce X-rays during operation and may require shielding. When e2v technologies IOTs are operated normally with the RF cavities fitted, some protection is provided but further shielding may be required. A suitably designed equipment cabinet will provide sufficient additional shielding. However, it is strongly recommended that all complete equipments containing operating IOT systems should be measured to establish that external X-ray levels comply with local regulations.



Mechanical

The circuit assembly has been designed to occupy the minimum of floor space in the transmitter. The wheel base is, therefore, short in relation to the height of the assembly, which has a high centre of gravity. Care is required when wheeling the magnet frame, and in particular, the IOT assembled in the magnet frame, over uneven surfaces or gradients which could cause the assembly to overbalance.



Hot Surfaces

Surfaces of tubes (for example the tube envelope in the gun region and the collector manifold in an air-cooled tube) can reach high temperatures (in some cases in excess of 100 °C) during operation and may remain at a high temperature for a considerable time after switch-off. Burns may be sustained if direct contact is made with hot surfaces.



Toxic

IOTs and ESCIOTs all contain industry standard cathode assemblies as part of the electron gun. The cathode assembly contains small quantities of various refractory metals. In normal operation, the presence of these materials requires no special precautions as they are sealed in vacuum. However, in the event of a catastrophic tube failure, resulting in loss of vacuum and exposure of a hot cathode to the atmosphere, these metals can form volatile oxides that are potentially hazardous to health. In such circumstances, operators should avoid inhaling vapours in close proximity to the tube and allow it to cool to room temperature before removing it from equipment. Broken tubes should be repacked carefully in their original packaging and returned to e2v technologies for safe disposal.

Whilst e2v technologies has taken care to ensure the accuracy of the information contained herein it accepts no responsibility for the consequences of any use thereof and also reserves the right to change the specification of goods without notice. e2v technologies accepts no liability beyond that set out in its standard conditions of sale in respect of infringement of third party patents arising from the use of tubes or other devices in accordance with information contained herein.