

FEATURING

- **Frequency Range** 470 to 860 MHz (Bands IV and V) in a single tube.
- **High Efficiency** 50% typical sync. efficiency at 74 kW output in standard operational mode at the least efficient channel. Corresponding greater Figures of Merit can be achieved by beam pulsing.
- **Output Power** Rated for 70 kW, 60 kW, 55 kW and 40 kW vision amplifier service.
- **Beam Control Device (BCD)** For low voltage beam current reduction during picture information.
- **Long Life** High reliability electron gun with barium aluminate cathode for longer tube life.
- **Simple, Efficient Cooling** Air-cooled body and cavities. Collector may be either vapour or water cooled using a simple boiler or water jacket.
- **Simple Tube Exchange** Continuously tunable external cavities, with digital frequency indicators. This means that a replacement tube will be coarse tuned on installation, needing only trimming adjustments.
- **Operational Mode Options** Klystron can be operated as a conventional TV klystron or the beam current can be pulsed.
- **All Ceramics Aluminium Oxide** No beryllium oxide ceramics.

DESCRIPTION

K3755 is a five cavity, high efficiency amplifier klystron for use in the output stages of sound and vision transmitters in UHF television service. The tube operates in the frequency range 470 to 860 MHz at sync. power levels up to 74 kW. A modulating anode is fitted, enabling:

- efficiency optimisation of beam voltage and current over the frequency range, and
- operation at reduced power levels in sound amplifiers using the same beam voltage supply as the vision amplifier.

In addition the electron gun incorporates a cylindrical, non-intercepting Beam Control Device for low voltage beam current modulation.

The tube is electromagnetically focused and the circuit assembly is designed to reduce tube replacement time to a minimum. The cavities can be detached from the vacuum tube and refitted on a replacement without disturbing the tuning, so that the replacement klystron is coarse tuned at switch-on and requires only loading loop setting and trimming adjustments to meet the full transmission specification. A feature of the cavity design is that tuning of both halves of each cavity is by means of a single knob. A digital indication of the cavity frequency is provided.

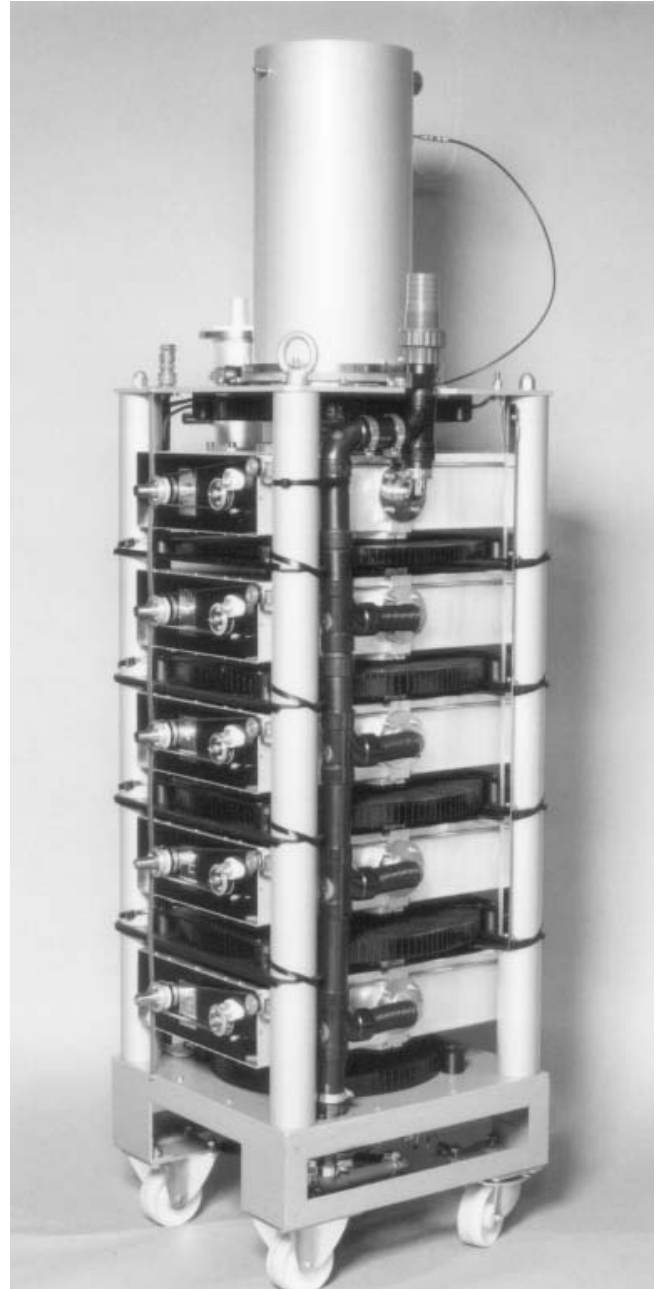

The electron gun, klystron body and cavities require forced-air cooling; the circuit assembly incorporates a distribution manifold. Cooling air must be adequately filtered to avoid electrostatic precipitation of dust on insulators.

The klystron collector may be either vapour cooled in a boiler with an upward steam exit from which the steam must be ducted to a separate condenser (not supplied), or water cooled in a water jacket from which the water must be led to a separate heat exchanger (not supplied).

ABRIDGED DATA

Frequency range (see note 1)	470 to 860	MHz
US channel numbers	14 to 69	
Sync. output power at klystron flange	up to 74	kW
Maximum drive power requirements:		
conventional operation	15	W
pulsed operation	50	W
Power gain (conventional operation)	35 to 45	dB
Beam voltage (for 74 kW sync. power)	25 to 28	kV
Modulating anode to cathode voltage (see note 2)	17.0 to 22.5	kV

GENERAL

Electrical

Cathode	indirectly heated
Heater voltage	8.0 ± 3% V dc
Heater current range	18 to 22 A
Black heat heater voltage (see note 3)	6.0 V dc
Cathode pre-heating time:	
from cold (see note 4)	5 minutes
from black heat (see note 5)	0 minutes
Ion pump to cathode voltage	+3.0 to 4.0 kV
Internal impedance of ion pump supply	500 kΩ approx

Mechanical

Overall length	173 cm (68.11 inches) nom
Overall diameter	28.25 cm (11.12 inches) nom
Mounting position	vertical, collector end up
Net weight of klystron	82 kg (180 pounds) approx

Circuit Assembly K4755 or K4755W

For vapour cooling of collector, order K4755.
For water cooling of collector, order K4755W.

Electromagnet current, stabilised to ± 2% (see note 6):	
vision klystron	9.5 to 12 A
sound klystron	9 to 12 A
Electromagnet resistance:	
cold	9.5 ± 1.0 Ω
hot (20 °C ambient)	14 Ω max
RF input connector	type N coaxial
RF output	3 1/8 inch 50 Ω coaxial line
Net weight of cavities	56 kg (125 pounds) approx
Net weight of magnet assembly	230 kg (505 pounds) approx

Cooling

Air flow to cavities and body (see note 7)	3.5 m ³ /min 125 ft ³ /min
Static pressure head (see note 8)	381 mm (15 inches) w.g.
Air flow to cathode terminal during black heat operation (see note 7)	0.14 m ³ /min 5.0 ft ³ /min
Air flow to drift tubes 5 and 6 (see notes 7 and 9)	1.4 m ³ /min each 50 ft ³ /min each

K4755 (vapour cooled) (see page 6):

volume of steam produced by collector dissipation	0.043 m ³ /min/kW 1.5 ft ³ /min/kW
volume of water converted to steam	0.027 l/min/kW 0.006 imp.gal/min/kW

K4755W (water cooled) (see page 6):

minimum water flow required	see page 6
maximum collector pressure drop	0.45 kg/cm ² 6.5 lb/in ²
inlet pressure to water jacket	100 lb/in ² max 7.0 kg/cm ² max
water outlet temperature (see note 10)	90 °C max
water inlet temperature	55 °C max

Arc Detector

Arc detector type MA257E is fitted to the third, fourth and output cavities. See page 12 for connection details.

Photo-resistor type	NSL 462
Minimum dark resistance	20 MΩ
Resistance at 1 foot-candle	28 kΩ
Resistance at 100 foot-candles	600 Ω
Maximum voltage (peak)	70 V
Maximum temperature	75 °C
Layer	cadmium sulphide
Test lamp	28 V 0.04 A
Connections	see page 12

MAXIMUM RATINGS (Absolute values)

If any maximum rating is exceeded, the beam voltage must be removed within 100 ms from the instant at which the rating is exceeded, and must not be re-applied within 5 s.

Heater voltage	9.5 V max
Heater starting current (peak)	65 A max
Beam voltage	30 kV max
Modulating anode to cathode voltage (see note 2)	23 kV max
Beam current	7.0 A max
Body current:	
with no input power	35 mA max
RF on (see note 11)	150 mA max
Modulating anode current	6.0 mA max
Mean output power	45 kW max
Collector dissipation	170 kW max
Load VSWR (see note 12)	1.5:1 max
Temperature of any part of tube envelope	175 °C max
BCD electrode voltage (see notes 13 and 14)	-1400 V max

TYPICAL OPERATION (BCD electrode at cathode potential)

70 kW vision amplifier

Frequency	470 to 476	638 to 644	800 to 806	MHz
US channel	14	42	69	
Beam voltage	26	27	28	kV
Modulating anode to cathode voltage (approx)	20.2	19.5	19.1	kV
Beam current	5.6	5.3	5.2	A
Body current:				
with no input power	12	10	10	mA
black level + sync.	80	45	35	mA
Sync. output power	74	74	74	kW
Saturated output power	76	76	76	kW
Electromagnet current	11	10	10	A
Peak drive power for 74 kW output (see note 15)	15	5	3	W
Sync. efficiency	50	51	50	%
Saturated efficiency	52	53	52	%
1 dB bandwidth	7.0	7.0	7.0	MHz

7.0 kW sound amplifier

US channel	14	42	69	
Beam voltage	26	27	28	kV
Modulating anode to cathode voltage (approx)	6.5	6.0	6.2	kV
Beam current	1.0	0.85	0.9	A
Output power	7.5	7.5	7.5	kW
Electromagnet current	10	9.0	9.0	A
Drive power	3	2	1	W
1 dB bandwidth	1.0	1.0	1.0	MHz

60 kW vision amplifier

Frequency	470 to 476	638 to 644	800 to 806	MHz
US channel	14	42	69	
Beam voltage	24	25	26	kV
Modulating anode to cathode voltage (approx)	19.8	18.8	18.7	kV
Beam current	5.4	5.1	5.0	A
Body current:				
with no input power	10	8.0	8.0	mA
black level + sync.	85	65	40	mA
Sync. output power	64	64	64	kW
Saturated output power	67	67	67	kW
Electromagnet current	11.0	10.5	10.0	A
Peak drive power for 64 kW output (see note 15)	15	5	3	W
Sync. efficiency	50	51	50	%
Saturated efficiency	52	53	52	%
1 dB bandwidth	7.0	7.0	7.0	MHz

6.0 kW sound amplifier

US channel	14	42	69	
Beam voltage	24	25	26	kV
Modulating anode to cathode voltage (approx)	5.7	5.4	5.2	kV
Beam current	0.8	0.75	0.7	A
Output power	6.5	6.5	6.5	kW
Electromagnet current	10	9.0	9.0	A
Drive power	3	2	1	W
1 dB bandwidth	1.0	1.0	1.0	MHz

TYPICAL OPERATION (Continued)

12 kW sound amplifier

US channel	14	42	69	
Beam voltage	24	25	26	kV
Modulating anode to cathode voltage (approx)	8.2	7.7	7.5	kV
Beam current	1.4	1.25	1.2	A
Output power	13	13	13	kW
Electromagnet current	10	9.0	9.0	A
Drive power	3	2	1	W
1 dB bandwidth	1.0	1.0	1.0	MHz

24 kW sound amplifier

US channel	14	42	69	
Beam voltage	24	25	26	kV
Modulating anode to cathode voltage (approx)	12.3	11.5	11.2	kV
Beam current	2.6	2.35	2.25	A
Output power	25.5	25.5	25.5	kW
Electromagnet current	11	10	10	A
Drive power	3	2	1	W
1 dB bandwidth	1.5	1.5	1.5	MHz

55 kW vision amplifier

Frequency	470 to 476	638 to 644	800 to 806	MHz
US channel	14	42	69	
Beam voltage	22	24	25	kV
Modulating anode to cathode voltage (approx)	20.1	18.4	18.2	kV
Beam current	5.4	4.8	4.7	A
Body current:				
with no input power	9.0	7.0	7.0	mA
black level + sync.	80	45	35	mA
Sync. output power	58	58	58	kW
Saturated output power	60	60	60	kW
Electromagnet current	11	10	10	A
Peak drive power for 58 kW output (see note 15)	15	5	3	W
Sync. efficiency	49	50	49	%
Saturated efficiency	51	52	51	%
1 dB bandwidth	7.0	7.0	7.0	MHz

5.5 kW sound amplifier

US channel	14	42	69	
Beam voltage	22	24	25	kV
Modulating anode to cathode voltage (approx)	5.9	5.2	4.9	kV
Beam current	0.85	0.7	0.65	A
Output power	6.0	6.0	6.0	kW
Electromagnet current	10	9.0	9.0	A
Drive power	3	2	1	W
1 dB bandwidth	1.0	1.0	1.0	MHz

TYPICAL OPERATION (Continued)

40 kW vision amplifier

Frequency	470 to 476	638 to 644	800 to 06	MHz
US channel	14	42	69	
Beam voltage	20.0	21.5	23.4	kV
Modulating anode to cathode voltage (approx)	17.9	16.7	16.0	kV
Beam current	4.65	4.15	3.95	A
Body current:				
with no input power	8.0	6.0	6.0	mA
black level + sync.	55	35	25	mA
Sync. output power	43	43	43	kW
Saturated output power	45	45	45	kW
Electromagnet current	11	10	10	A
Peak drive power for 43 kW output (see note 15)	15	5	3	W
Sync. efficiency	46.0	48.4	46.8	%
Saturated efficiency	48.1	50.7	49.0	%
1 dB bandwidth	7.0	7.0	7.0	MHz

4.0 kW sound amplifier

US channel	14	42	69	
Beam voltage	20.0	21.5	23.4	kV
Modulating anode to cathode voltage (approx)	5.4	4.9	4.3	kV
Beam current	0.75	0.65	0.55	A
Output power	4.5	4.5	4.5	kW
Electromagnet current	9.5	9.0	9.0	A
Drive power	3	2	1	W
1 dB bandwidth	1.0	1.0	1.0	MHz

NOTES

- For operation data beyond US channel 69, please consult e2v technologies.
- The modulating anode voltage must not be positive with respect to the klystron body. The modulating anode should be connected to its supply via a 10 k Ω resistor. A voltage divider for adjusting the cathode current should allow for a typical modulating anode current of 2.5 mA.
- Continuous periods of black heat operation should not exceed two weeks and should be separated by similar periods of rest or full operation.
- In the event of a power failure a maximum interruption time of 30 seconds can be tolerated without the need for a repeated cathode pre-heating time.
- For black heat operation, a heater voltage of 6.0 V must have been applied to the klystron heater for a minimum of 10 minutes before the beam voltage may be switched on. On application of the beam voltage the heater voltage must simultaneously be increased to 8.5 V.
- Under TV picture conditions the klystron will focus satisfactorily within the specified range. For maximum stability, adjust the magnet current for best TV performance and stabilise to $\pm 2\%$ about this optimum value.
- This value applies to transmitters at sea level where the air density is 1.22 kg/m³ (0.076 lb/ft³). At high altitudes where air density is significantly reduced the volume flow must be increased in the ratio of air density at sea level to air density at altitude in order to maintain the mass flow.
- Measured by a manometer at the input pipe to the circuit assembly.
- For operation at 60 kW or more the air pipes on the manifold to the final and penultimate drift tubes must be blocked and an additional air flow of 1.4 m³/min (50 ft³/min) blown at each of these drift tubes through rectangular ducts of 45 cm² (7 in²) cross-section.
- For operation at high altitude where atmospheric pressure is reduced and water boils at a lower temperature, the maximum water outlet temperature is 10 °C below the boiling point at that altitude.
- The combined body current of one sound and one vision klystron in parallel will not exceed the limit specified.
- This value applies to television service. e2v technologies should be consulted regarding other conditions of service.

13. The K3755 may be operated with a pulsed voltage applied to the BCD electrode. This enables the beam power to be decreased during the picture region of the video signal so that up to 74 kW sync. pulses can be produced at the klystron flange with an appreciable reduction in mean beam power.

The following conditions must be observed when operating in this mode:

- (a) The BCD voltage must never be positive with respect to cathode.
- (b) The BCD voltage must not exceed -1400 V with respect to cathode.

The effect of increasing the negative BCD voltage with respect to the cathode is to reduce the beam current. This effect is shown in the BCD electrode voltage characteristic graph (see page 8).

14. To measure the BCD current, the klystron must be operated undisturbed for a period of **45 minutes** under the following conditions.

Beam voltage	21.5	kV
Modulating anode to cathode voltage	21.5	kV
Heater voltage	8.5	V
BCD to cathode voltage	-1.0	kV

The BCD current will typically be less than 1 mA on a new klystron and is warranted not to exceed 2 mA during the warranty period; in some cases it may exceed 2 mA during the remainder of the tube's life. To ensure that maximum useful life is achieved from all klystrons, the BCD drive circuit should be able to give the required voltage variations at currents well in excess of 2 mA.

With a BCD-to-cathode voltage of -1.0 kV , a beam current reduction of about 35% should be expected. In a typical transmitter with appropriate pulsing, RF drive and correction arrangements, corresponding increases in Figure of Merit can be obtained.

Typical values of interelectrode capacitance are:

BCD to cathode	80	pF
Cathode to modulating anode (BCD connected to cathode)	35	pF
Modulating anode to klystron body	30	pF

Appropriate measures must be taken to protect the klystron and the pulse drive in the event of a DC arc between the BCD electrode and anode.

15. Defined as the power delivered to a matched load substituted for the input cavity of the klystron.

TEMPERATURE SENSOR MA971A

Temperature sensor type MA971A is a platinum film resistance type sensor for monitoring the temperature of the klystron collector when being water or vapour cooled. The sensor conforms to BS1904 and DIN 43760. The resistance-temperature relationship is shown below.

The resistance element is insulated from the body of the probe unit. The resistance between element and probe is typically better than $10\text{ M}\Omega$ at $20\text{ }^\circ\text{C}$.

The probes are tested to 240 V dc between probe and element.

Protective circuits must be provided so that the probe body (collector potential) to resistance element voltage does not exceed 200 V , even under short-term fault conditions.

To avoid errors due to element heating and damage to the resistance element, circuits should be designed to draw as little current as possible through the element. The recommended maximum current is 3 mA.

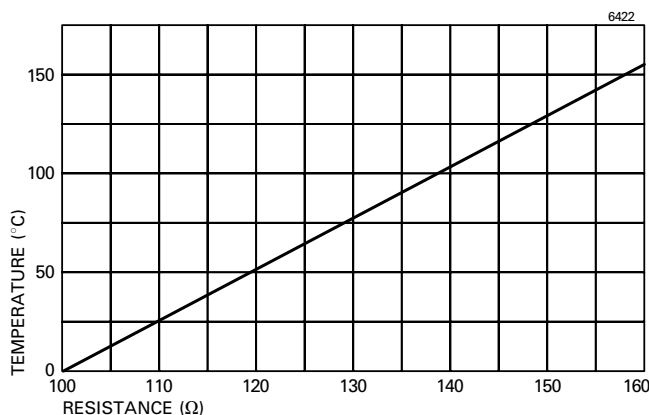

RECOMMENDED COOLANTS

K4755W (Liquid Cooled)

In the liquid cooled mode, when there is no danger from freezing, the coolant should be good quality demineralised water. Where outside ambient temperatures are such that there is a danger that pure water will freeze, the coolant should be a mixture of equal volumes of pure demineralised water and a commercial glycol anti-freeze preparation containing appropriate corrosion inhibitors and pH buffers. The coolant flow will need to be increased when the glycol-water mixture is in use (see graph for flow rates).

Glycol anti-freeze mixtures are liable to thermal degradation with prolonged life, especially where the coolant is oxygenated. Cooling system designers should ensure that oxygenation of the coolant is avoided wherever possible by, for example, ensuring that return pipes discharge below the level of coolant in the reservoir tank. Commercial glycol preparations such as Dowcal 10 or Dowtherm SR-1 have been examined by e2v technologies and are believed to contain suitable inhibitor and pH buffer additives.

It is recommended that the glycol coolant is discarded after being used for one winter season. The transmitter should then be operated with demineralised water during the summer before changing to a new glycol solution for the next winter. The long term use of commercial grade, un-buffered and uninhibited ethylene glycol will lead to corrosive damage to the transmitter cooling system and consequential damage to the klystron. Such coolants may only be used for a short time (not more than one week) in an emergency.

When the klystron is operated as a sound amplifier, a minimum coolant flow rate of 20 l/min for distilled water or 22 l/min for a 50:50 glycol/water mixture must be used.

K4755 (Vapour Cooled)

Only pure demineralised water should be used in the boiler; local water supplies are usually suitable only for the secondary circuit of a water cooled condenser.

LIQUID COOLING REQUIREMENTS FOR K4755W

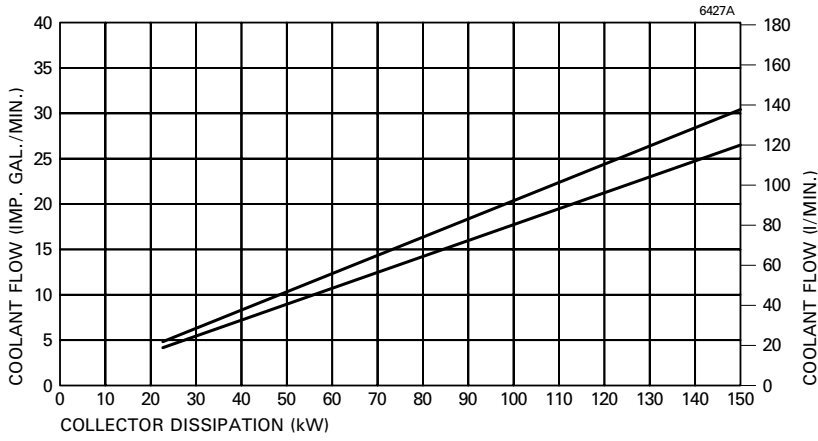

Note 1 US gal = 0.832 Imp. gal.

BEAM CURRENT CHARACTERISTIC (BCD electrode at cathode potential)

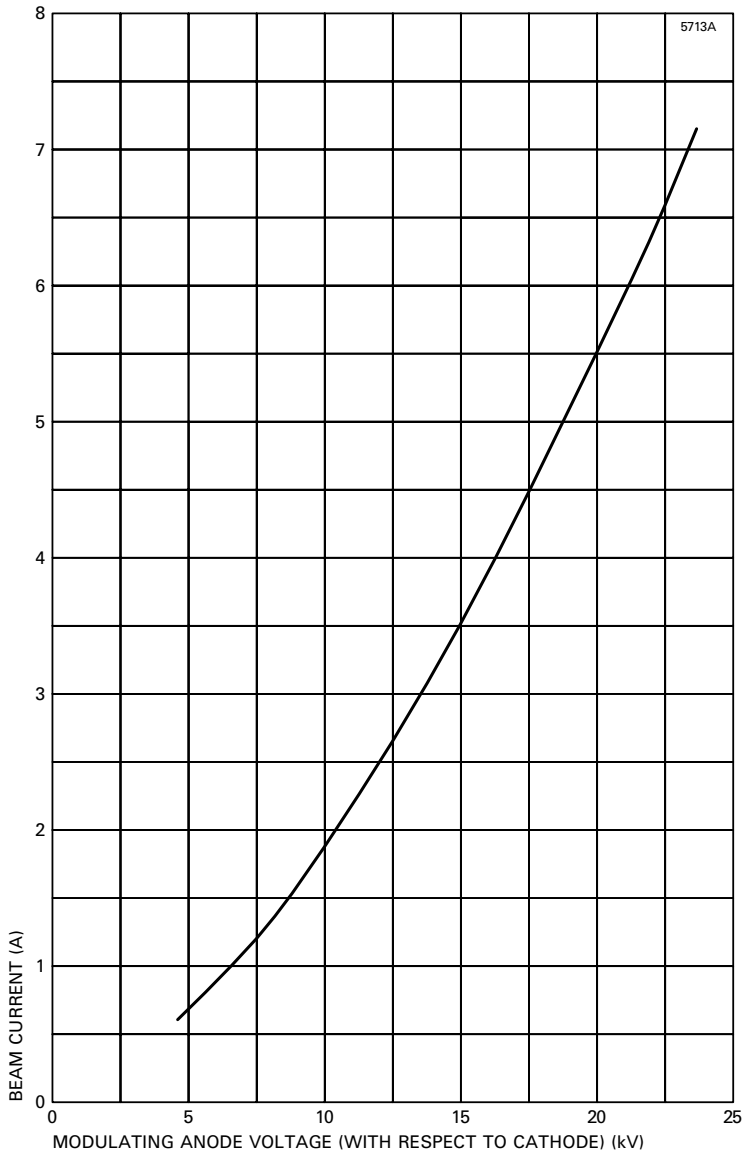

BCD ELECTRODE VOLTAGE CHARACTERISTICS

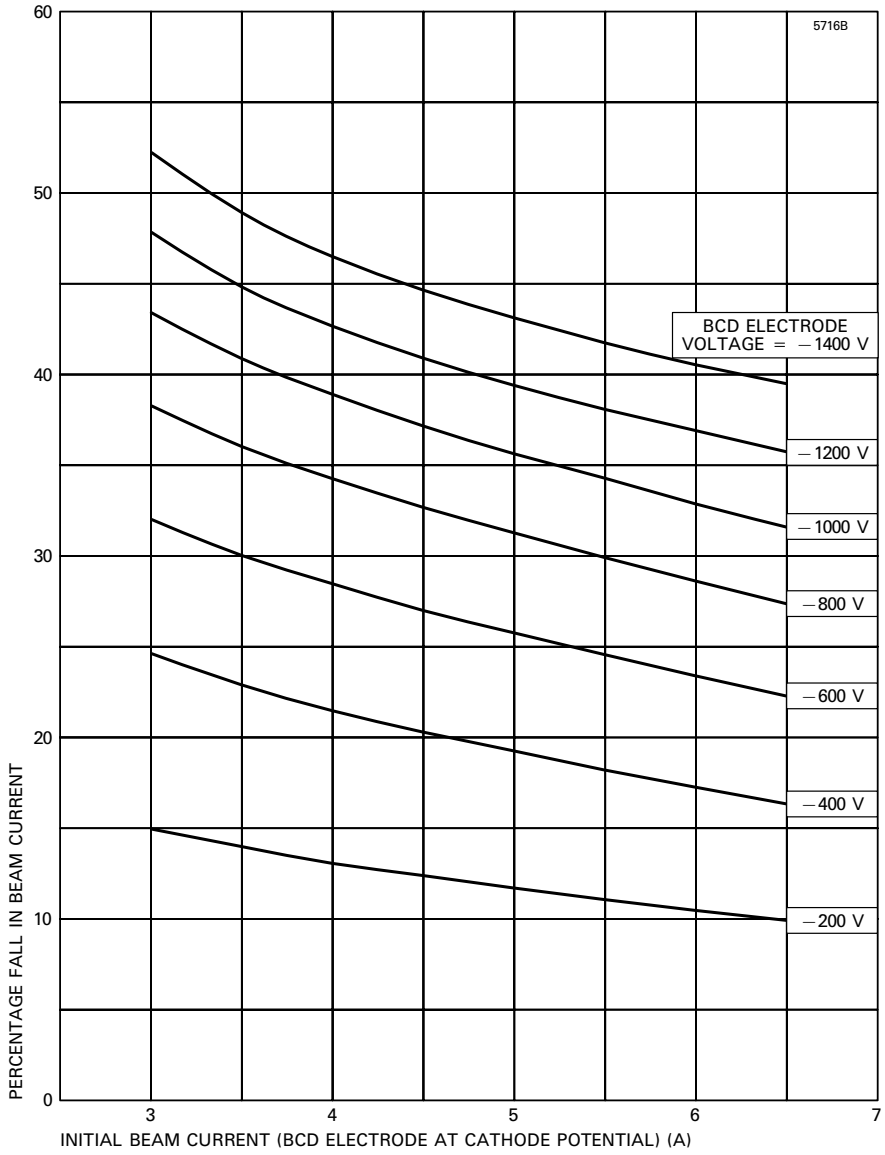

OUTLINE OF K3755 (All dimensions nominal)

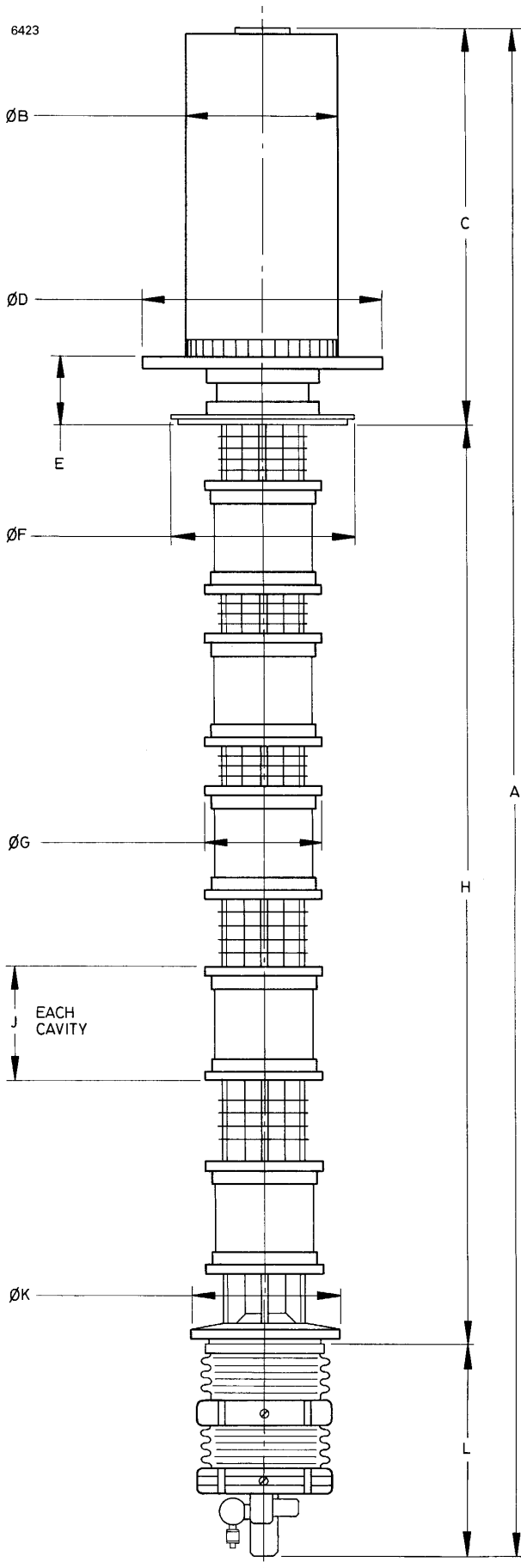

Ref	Millimetres	Inches
A	1730.0	68.110
B	175.0	6.890
C	466.5	18.366
D	282.5	11.122
E	75.4	2.969
F	202.0	7.953
G	130.2	5.126
H	1032.5	40.650
J	127.0	5.000
K	160.0	6.299
L	225.0	8.858

Inch dimensions have been derived from millimetres.

Enlarged View on Gun End of Klystron

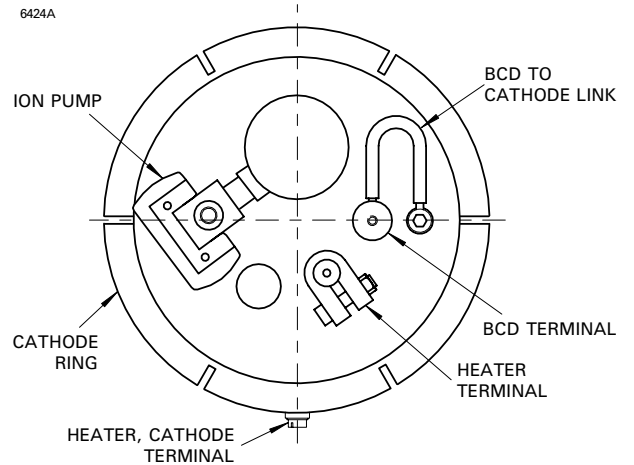

Note The klystron is supplied with a shorting link connected between the BCD terminal and cathode. *If the BCD electrode is to be used, this link must be removed.*

OUTLINE OF CIRCUIT ASSEMBLY K4755W (All dimensions without limits are nominal)

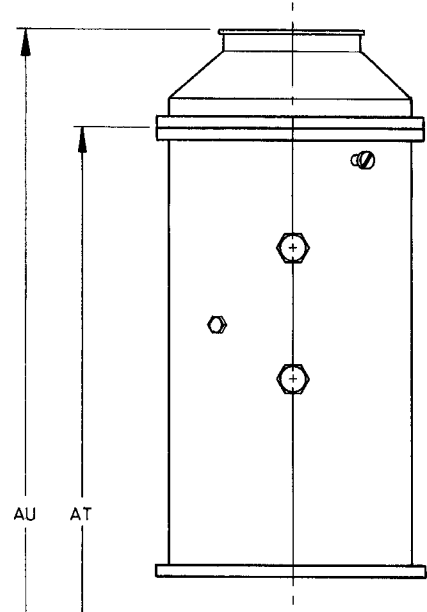
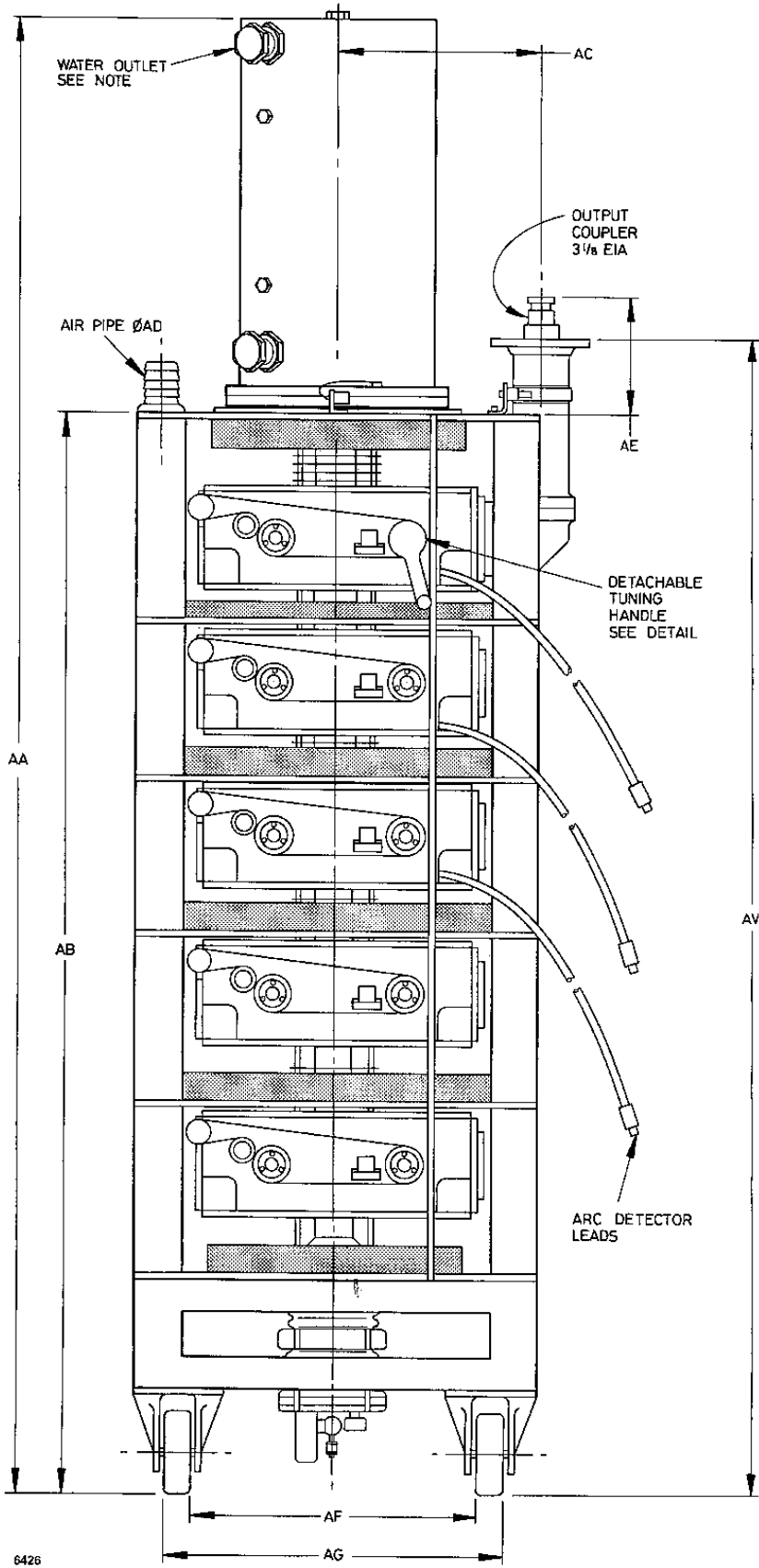

**Detail of K4755
Boiler Unit**

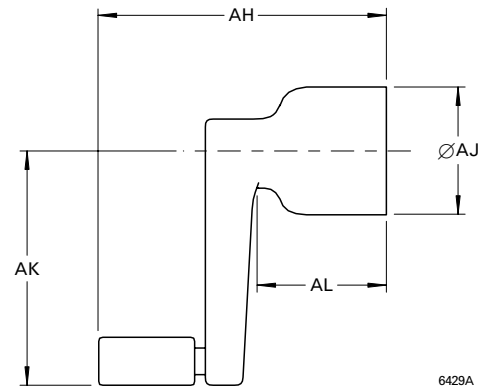

**Detail of MA992A
Tuning Handle**

6425

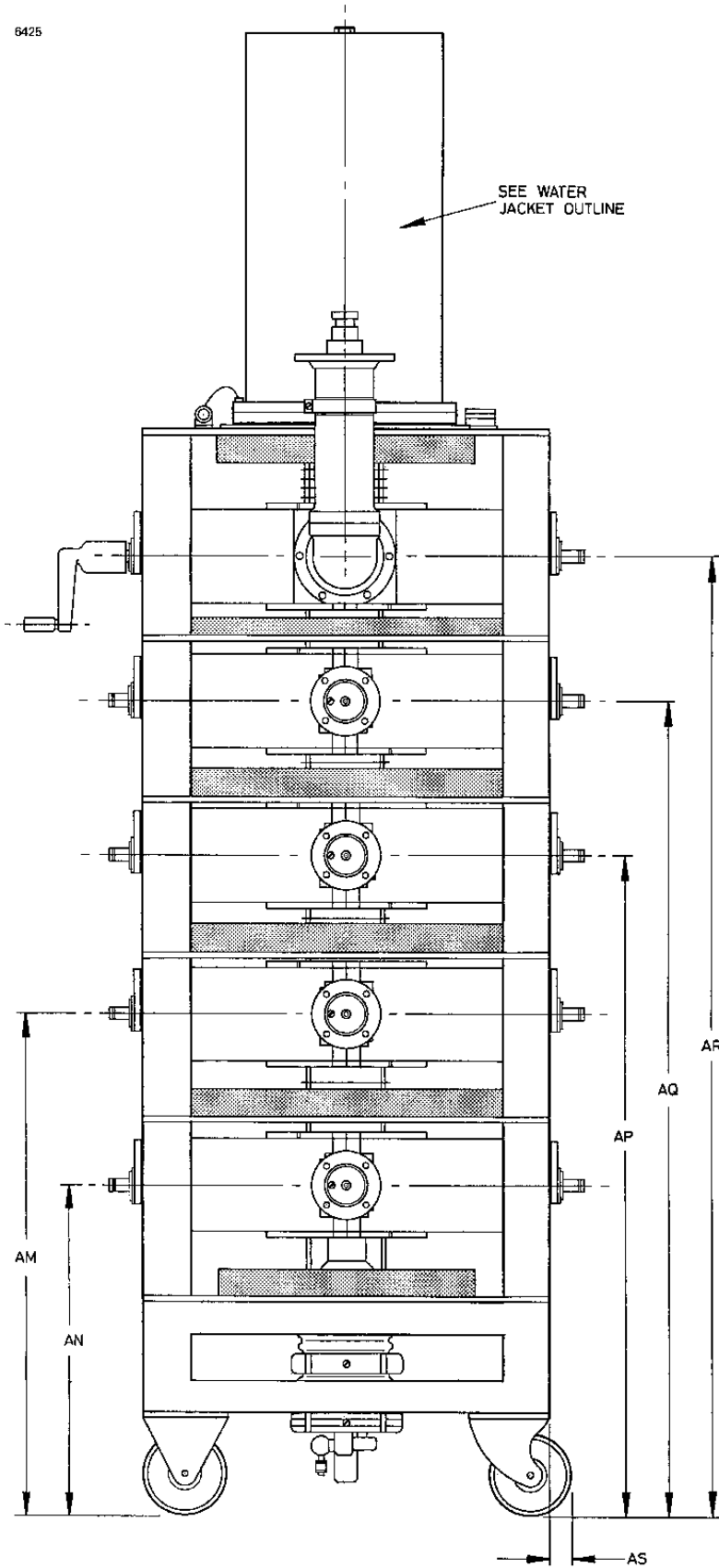

Ref	Millimetres	Inches
AA	1846.65	72.703
AB	1366.1	53.783
AC	265.0	10.433
AD	50.0	1.969
AE	150.0	5.906
AF	320.0	12.598
AG	405.0	15.945
AH	130.0	5.118
AJ	40.0	1.575
AK	90.0 max	3.543 max
AL	60.0	2.362
AM	630.0	24.803
AN	415.0	16.339
AP	830.5	32.697
AQ	1023.5	40.295
AR	1208.0	47.559
AS	45.0	1.772
AT	1819.5	71.63
AU	1922.5	75.69
AV	1460.1	57.48

Inch dimensions have been derived from millimetres.

Note Orientation of boiler or water jacket set by the user to bring connections to most convenient position.

TOP VIEW OF CIRCUIT ASSEMBLY K4755W (All dimensions nominal)

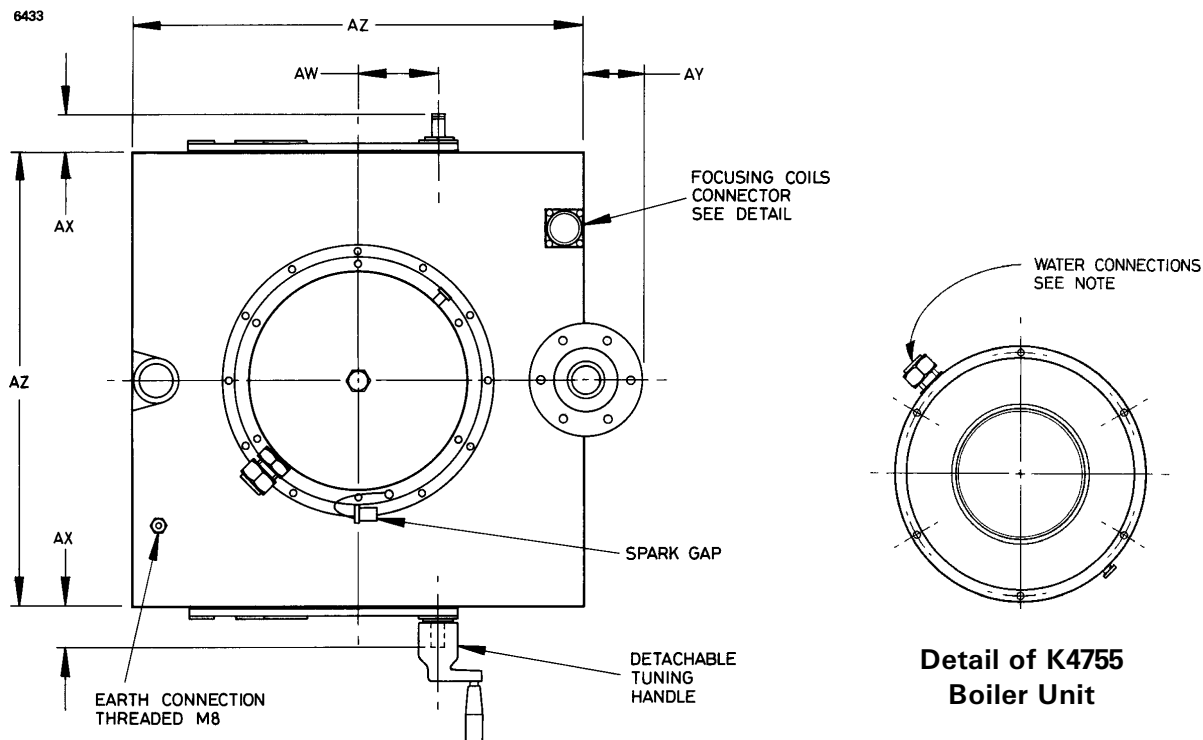

Ref	Millimetres	Inches
AW	88.0	3.465
AX	55.0	2.165
AY	78.0	3.071
AZ	508.0	20.000

Inch dimensions have been derived from millimetres.

Note Orientation of boiler or water jacket set by the user to bring connections to most convenient position.

Arc Detector Connections to socket type Amphenol T3476-001

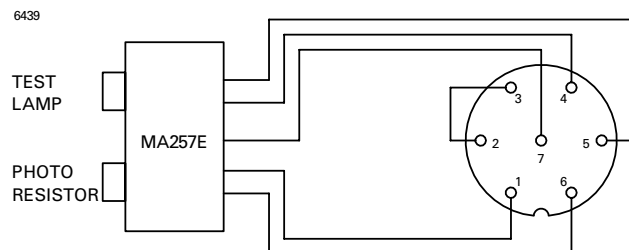

MA257E uses a panel plug and free socket.

View on Focus Coil Connector

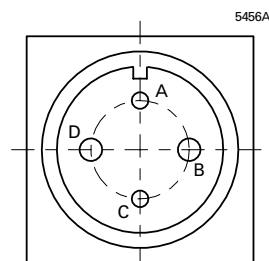

Connections

Pin	Element
A	Focus coil positive
B	Interlock
C	Focus coil negative
D	Interlock

Pins B and D are connected within the circuit assembly for use as an interlock circuit; this connection may be removed by the customer if required for other purposes.

OUTLINE OF BOILER UNIT (All dimensions without limits are nominal)

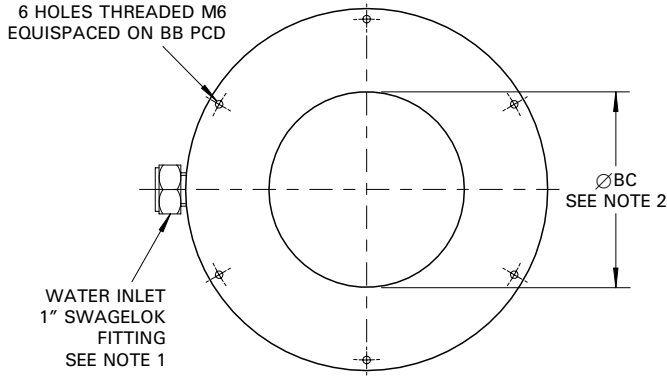

6430A

Ref	Millimetres	Inches
BA	433.0 ± 0.5	17.047 ± 0.020
BB	266.0	10.472
BC	152.5	6.004
BD	13.0 ± 0.4	0.512 ± 0.016
BE	282.5	11.122
BF	10.0	0.394
BG	55.5	2.185
BH	248.0	9.764
BJ	7.25 ± 0.25	0.285 ± 0.010
BK	266.0	10.472
BL	103.0 ± 0.5	4.055 ± 0.020
BM	168.4 ± 0.1	6.630 ± 0.004

Inch dimensions have been derived from millimetres.

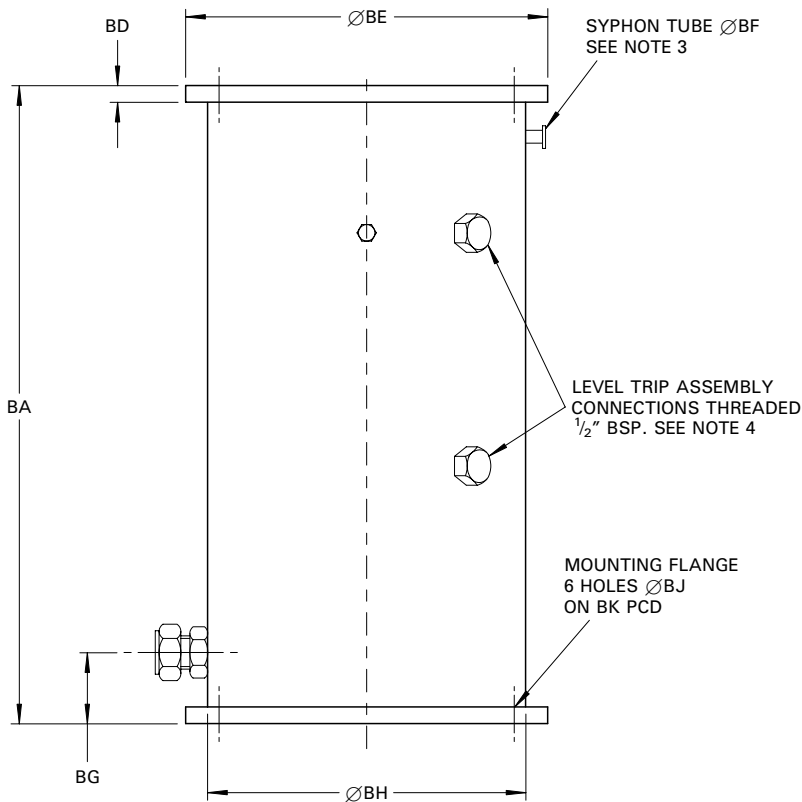

Detail of Boiler Adaptor (See note 5)

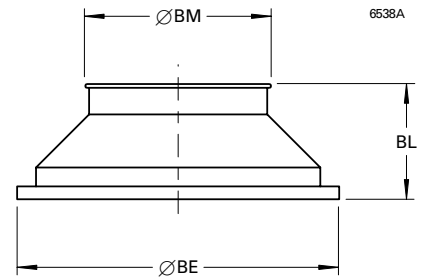

Notes

1. A weir, designed to maintain the water level in the boiler constant when operating with a pumped system, is available from e2v technologies, part no. MA963D. A circuit assembly type K4755J, incorporating a boiler fitted with a weir and level trip is available.
2. To ensure efficient separation of carried over water from the steam, a vertical section of 152 mm (6-inch) nominal bore steam pipe at least 457 mm (18 inches) long must be coupled to the boiler steam outlet. The remainder of the steam pipe may be reduced to 102 mm (4-inch) nominal bore.
3. Water drain outlet; do not remove cap when klystron is operating. To drain boiler, remove cap and attach the syphon provided.
4. A sight glass and level trip assembly to fit the boiler is available from e2v technologies, part no. MA213A.
5. The boiler adaptor is an integral part of the cooling system and under no circumstances must the system be operated without it being in position.

OUTLINE OF WATER JACKET (All dimensions without limits are nominal)

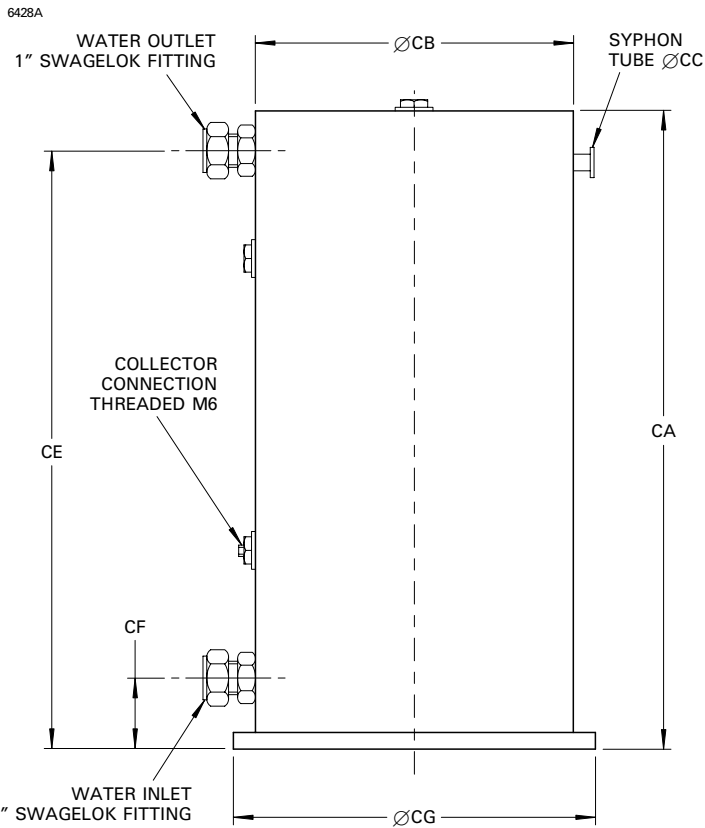

Ref	Millimetres	Inches
CA	473.0 \pm 0.5	18.622 \pm 0.020
CB	248.0	9.764
CC	10.0	0.394
CE	442.0 \pm 1.0	17.402 \pm 0.039
CF	55.0 \pm 1.0	2.165 \pm 0.039
CG	282.5 \pm 0.4	11.122 \pm 0.016

Inch dimensions have been derived from millimetres.

HEALTH AND SAFETY HAZARDS

High power klystrons can be hazardous to life and health if they are not installed, operated and maintained correctly, or if a klystron is damaged. e2v technologies does not accept responsibility for damage or injury resulting from the use of e2v technologies klystrons. Equipment manufacturers and klystron users should ensure that precautions are taken. Appropriate warning labels and notices must be provided on equipment incorporating klystrons and in operating manuals.



High Voltage

Equipment must be designed so that operators cannot come into contact with high voltage circuits. Klystron enclosures should have fail-safe interlocked switches to disconnect the primary power supply and discharge all high voltage capacitors before allowing access.



RF Radiation

Personnel must not be exposed to excessive RF radiation. All RF connectors and cavities must be correctly fitted before operation, so that there is no leakage of RF energy. Klystrons must not be operated without a suitable RF load at the output and intermediate cavities. It is particularly dangerous to look into open waveguide or coaxial feeders, or transmitter antennae.



X-Ray Radiation

All high voltage devices produce X-rays during operation and may require shielding. When e2v technologies klystrons are operated normally with the RF cavities fitted, some protection is provided but further shielding may be required. A suitably designed equipment cabinet will provide sufficient additional shielding. However, it is strongly recommended that all complete equipments containing operating klystron systems should be measured to establish that external X-ray levels comply with local regulations.



Mechanical

The circuit assembly has been designed to occupy the minimum of floor space in the transmitter. The wheel base is, therefore, short in relation to the height of the assembly, which has a high centre of gravity. Care is required when wheeling the magnet frame, and in particular, the klystron assembled in the magnet frame, over uneven surfaces or gradients which could cause the assembly to overbalance.



Hot Surfaces

Surfaces of tubes (for example the tube envelope in the gun region and the boiler in a vapour cooled system) can reach high temperatures (in some cases in excess of 100 °C) during operation and may remain at a high temperature for a considerable time after switch-off. Burns may be sustained if direct contact is made with hot surfaces.

Whilst e2v technologies has taken care to ensure the accuracy of the information contained herein it accepts no responsibility for the consequences of any use thereof and also reserves the right to change the specification of goods without notice. e2v technologies accepts no liability beyond that set out in its standard conditions of sale in respect of infringement of third party patents arising from the use of tubes or other devices in accordance with information contained herein.